

# Bomba Dupla de Palhetas Variável

## VCMDF12, VCMDF20, VCMDF30 e VCMDF40

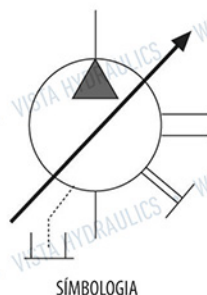
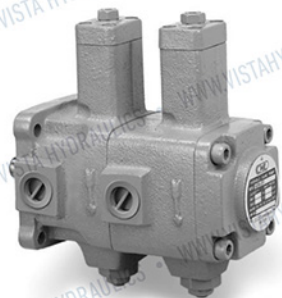

### Características

1. Alta eficiência com mínimo de perda de potência.
2. Baixo ruído.
3. Compacta e fácil de operar.
4. Estrutura resistente para uma vida útil longa e de alta eficiência.

### Solicite pelo código

VCM - DF - 30 - B / 30 B 10

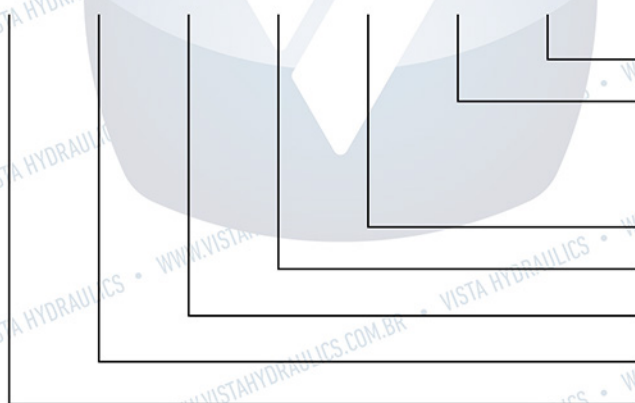

**Desenho**

**Faixa de Pressão (bar)**

A:20 C:55

B:35 D:70

**Vazão da Bomba Secundária**

**Vazão de Pressão Bomba Dianteira**

**Vazão da Bomba Dianteira**

**Série Dupla**

**Bomba de Palhetas de Vazão Variável**

# Informações Técnicas

MODELO	VAZÃO (l/min)		FAIXA DE PRESSÃO (bar)	ROTAÇÃO		PRESSÃO MÁXIMA (bar)	PESO (kg)
	1800rpm	1500rpm		Max	Min		
V CM DF-12A	12	10	10-20	1800	800	20	5.0
V CM DF-12B			15-35			35	5.0
V CM DF-12C			30-55			55	5.0
V CM DF-12D			50-70			70	5.0
V CM DF-20A	20	17	10-20	1800	800	20	5.0
V CM DF-20B			15-35			35	5.0
V CM DF-20C			30-55			55	5.0
V CM DF-20D			50-70			70	5.0
V CM DF-30A	30	25	10-20	1800	800	20	9.0
V CM DF-30B			15-35			35	9.0
V CM DF-30C			30-55			55	9.0
V CM DF-30D			50-70			70	9.0
V CM DF-40A	40	35	10-20	1800	800	20	9.0
V CM DF-40B			15-35			35	9.0
V CM DF-40C			30-55			55	9.0
V CM DF-40D			50-70			70	9.0

V CM DF-12\*-10

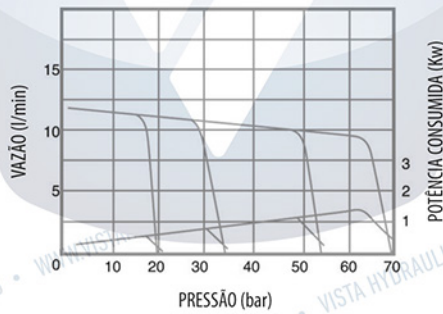

V CM DF-20\*-10

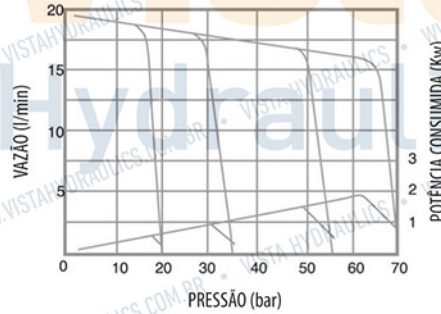

V CM DF-30\*-10

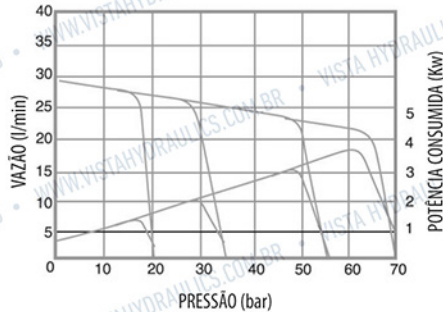

V CM DF-40\*-10

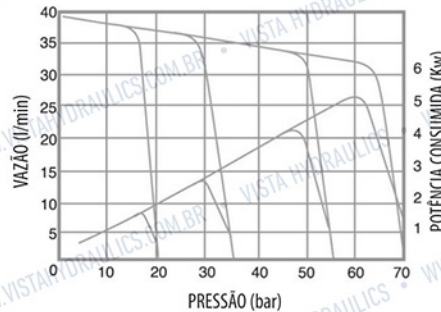

## Dimensões

V CM-DF-12\*-12\*-10

V CM-DF-20\*-20\*-10

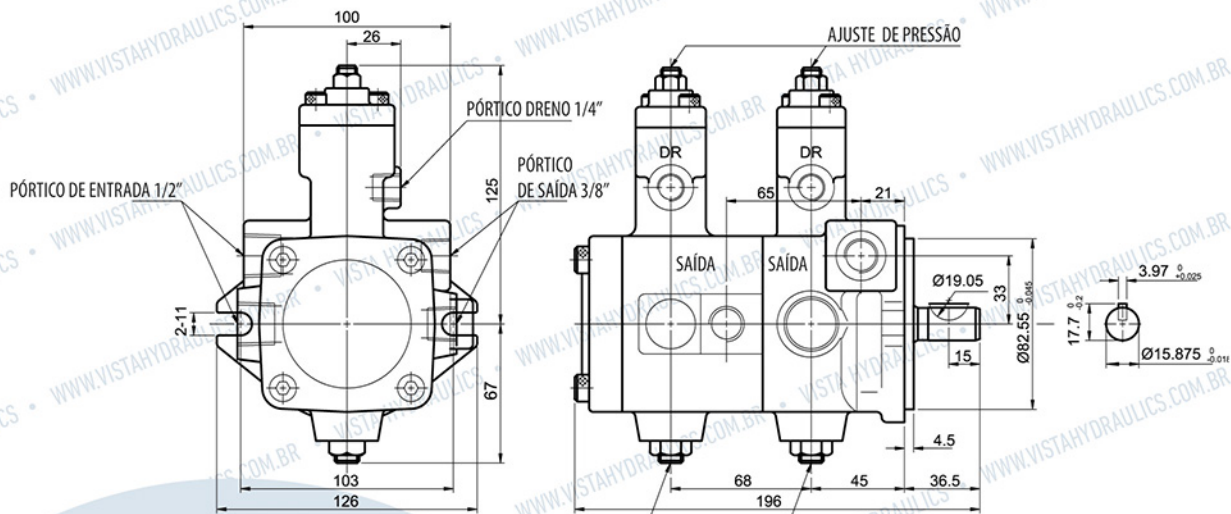

V CM-DF-30\*-30\*-10

V CM-DF-40\*-40\*-10

